



## FILL SWIVEL ADAPTERS

The fill swivel adapter helps prevent leaks caused by constant fill delivery elbow movement on the riser adapter. The top section rotates during normal deliveries, preventing the bottom section from loosening on the riser pipe which could cause a vapor or product leak around the adapter.

### HIGHLIGHTS

- Adds approximately 4" to riser height to fit under most existing fill and vapor manway covers.
- Swivels on two rows of corrosion-resistant chromium steel ball bearings for long life in high volume stations.
- All vapor seals are fluorocarbon and inert in motor fuels.
- Stainless steel models provide additional fuel compatibility and are CARB Phase I EVR approved under executive order VR-101.
- Available in packages including fill and vapor adapter.
- Available in kits including riser, cap, and swivel adapter.

### SPECIFICATIONS

#### Components

- 1 Cap
- 2 Swivel adapter
- 3 Riser nipple
- 4 Spill container

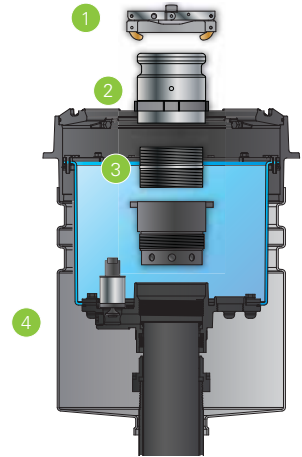

### ORDERING INFORMATION

#### Fill Swivel Adapters



Model	Description
SWF-100-SS**	Fill swivel adapter, 4" NPT, stainless steel
SWF-100-B*	Fill swivel adapter, 4" NPT, brass
SWFV-PKGSS**	Vapor and fill swivel adapter kit, 4" NPT, stainless steel
SWFV-PKG*	Vapor and fill swivel adapter kit, 4" NPT, brass
85039	Replacement gasket for all swivel adapters

\*EVR Phase 1 Certification VR-101.

\*\*EVR Phase 1 Certification VR-101 for gas and E85.

#### Fill Swivel Adapter Kits

Be sure to select the appropriate kit for your specific spill container type.



Model	Description
70541202	Fill swivel adapter kit for 5 gallon Defender Series® (grade level and below grade level) and EBW® Series (grade level) spill containers, includes stainless steel fill swivel adapter, 3" riser nipple, vapor top cap.
70541201	Fill swivel adapter kit for 5 gallon PHIL-TITE™ and EBW® Series (below grade) spill containers, includes stainless steel fill swivel adapter, 5" riser nipple, vapor top cap.
70541203	Fill swivel adapter kit for 15 gallon EBW® Series (below grade) spill containers, includes stainless steel fill swivel adapter, 12" riser nipple, vapor top cap.